

Ultrasonic Water Meter Instructions LXC-50D-200D



CONTENT

Part 1	Product Introduction.....	- 1 -
1	Overview.....	- 1 -
2	Uses.....	- 1 -
3	Function.....	- 1 -
4	Product Components.....	- 2 -
5	Product Implementation Standards.....	- 2 -
Part 2	Installation and Use.....	- 3 -
1	Water Meter Caliber Selection.....	- 3 -
2	Installation of Water Meter.....	- 3 -
3	water meter installation precautions.....	- 4 -
4	Instructions.....	- 5 -
Part 3	Dimensions.....	9
Part 4	Disclaimer.....	10
Part 5	Transportation and Storage.....	10
Part 6	Troubleshooting.....	10

Tables

Table 2-1 Flow Parameter	8
Table 3-1 Dimensions -sketch map	9
Table 3-2 Product accessories list	10

Figures

Table 2-1 Flow Parameter	8
Table 3-1 Dimensions -sketch map	9
Table 3-2 Product accessories list	10

Part 1 Product Introduction

1 Overview

Ultrasonic water meter is a new type of water meter that detects the time difference caused by the change of the speed when the ultrasonic beam propagates in the opposite direction of the water, and analyzes and processes the flow rate of the water to further calculate the flow rate of the water.

2 Uses

It can be widely used in water supply metering of water companies to measure drinking cold water flowing through tap water pipes.

3 Function

3.1 The main menu of the ultrasonic water meter displays the cumulative flow rate (m^3), flow rate (m^3/h), water temperature ($^{\circ}\text{C}$), water meter number, accumulated working time, fault information, etc.

3.2 No rotating parts. Ensuring long-acting dose under various complicated conditions with ultrasonic measurement principle;

3.3 Low power consumption, accuracy: class B

3.4 Communication interface standard infrared, M-Bus remote transmission interface, can provide a variety of communication interfaces for customers to choose according to demand (such as: MBUS, RS485, pulse, wireless 470MHz, wireless GPRS), can achieve remote meter reading Features, easy to manage and save on operating costs.

3.5 Support real-time data communication to ensure the accuracy and timeliness of data.

3.6 Automatic diagnosis of a variety of abnormal alarm functions, error information can be displayed on the LCD and can also be uploaded to the management system through remote data acquisition, timely alarm, notify the maintenance service to ensure that the instrument and the pipe network are operating normally.

3.6.1 Battery power detection: When the voltage is insufficient, it is displayed on the LCD screen and can be uploaded to the management system through remote transmission.

3.6.2 Flow signal detection: When there is no water in the pipeline and the transducer has no signal, the system automatically prompts and stores the error message and alarms.

3.6.3 Pipeline leak detection: The flow signal continues to run for a long time (such as 24 hours), indicating that there is continuous movement of water for a long time. It may be that the toilet is not closed at home, the water tap is not closed, the water leaks, and the system automatically prompts and stores the error message. And alarm.

3.6.4 Pipe burst detection: If the water meter detects a large flow for more than half an hour, the system automatically prompts, stores the error message, and alarms.

3.6.5 Water flow direction detection: There are arrows on the surface of the water meter to indicate the installation direction and water flow direction. However, due to negligence or other reasons, the water meter is reversed during actual installation. When there is a water flow type water meter program, the water flow direction is automatically detected, when the water flow direction is When the direction of the arrow is reversed, the system automatically prompts, stores the error message, and alerts.

3.7 Professional piping design to ensure the stability of the measured water field.

4 Product Components

4.1 Ultrasonic pipeline:

It is used to install the ultrasonic generator-transducer pipeline, which has the function of water field rectification, steady flow and optimization of ultrasonic signal propagation.

4.2 Transducer:

It is an ultrasonic sound emitting or receiving device, an electroacoustic converting device made of piezoelectric ceramic material.

4.3 Temperature sensor:

Installed on the ultrasonic pipeline to collect the temperature of the measured medium to correct the temperature of the ultrasonic signal.

4.4 Calculator:

Receive signals from flow sensors and temperature sensors for flow calculation, storage, display systems, data transmission, etc.

5 Product Implementation Standards

- *GB/T778.1-2007 Measurement of Water Flow in Closed Full Pipes - Drinking Cold Water and Hot Water Meters - Part 1: Specification*
- *BT 778.2-2007 Measurement of Water Flow in Closed Full Pipes - Drinking Cold Water Meters and Hot Water Meters - Part 2 Installation requirements*
- *GBT 778.3-2007 Measurement of Water Flow in Closed Full Pipes - Drinking Cold Water Meters and Hot Water Meters - Part 3 Test Methods and Test Equipment*
- *"CJT 434-2013 Ultrasonic Water Meter"*
- *"JJG 162-2009 Cold Water Meter Verification Regulations"*

Part 2 Installation and Use

1 Water Meter Caliber Selection

Should be based on the amount of water to close to the usual flow rate, rated working conditions:

- 1.1 Flow range: $Q_1 \sim Q_3$;
- 1.2 Ambient Temperature: $5^{\circ}\text{C} \sim 55^{\circ}\text{C}$;
- 1.3 Water Temperature: cold water meter $0.1^{\circ}\text{C} \sim 30^{\circ}\text{C}$;
- 1.4 Ambient temperature is $(0 \sim 100)\%$ RH at 40°C ;
- 1.5 Water Pressure: $0.03 \sim 1.0\text{Mpa}$, the water meter should not be used to pass corrosive liquid, and the cold water meter is forbidden to pass hot water.

2 Installation of Water Meter

2.1 Avoid sun, rain, freezing, pollution, water splashing and flooding, and easy to disassemble.

2.2 During the freezing period, in addition to wrapping the water meter and the water pipe, when not in use, the water inlet valve of the water meter is closed, and the water discharge valve and the faucet are opened to prevent the water meter from being damaged due to freezing expansion.

2.3 The arrow of the case is in the same direction as the flow of the pipe. The upstream of the water meter should be equipped with a control valve to facilitate the maintenance of the water meter (Figure 2-1).

2.4 The water meter can be installed horizontally and vertically, but it must be installed in the upper water level. There are enough straight pipes before and after the table (Figure 2-2).

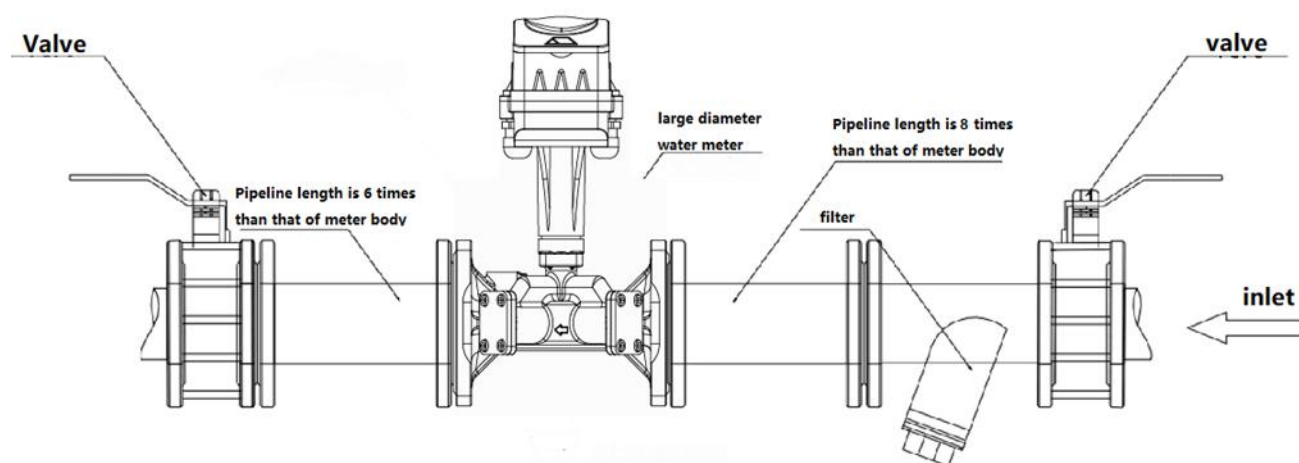

Figure 2- 1 Water Meter Installation Diagram (1)

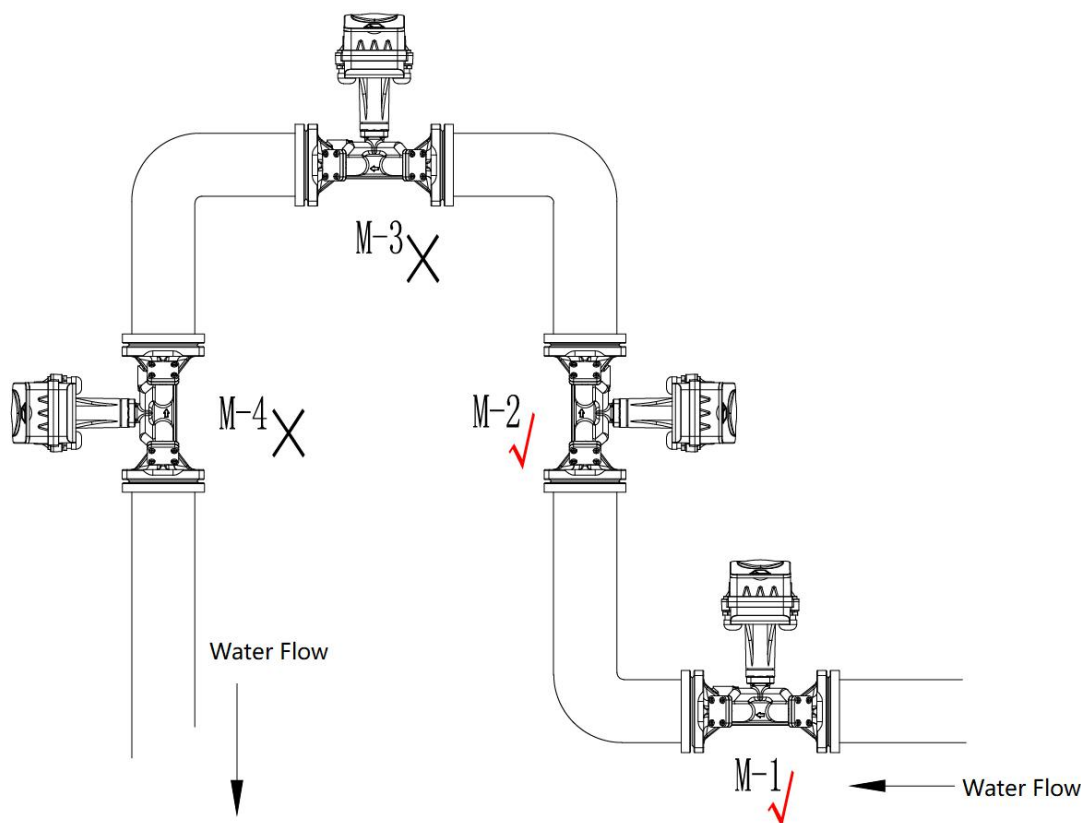

Figure 2- 2 Water Meter Installation Diagram (2)

- ◆ In the figure, M-1 and M-2 show the correct installation method (M-1 is horizontal installation and M-2 is vertical installation). The water meter is installed under the pipeline, and there is back pressure at the back end of the water meter, which will not affect the bubble measurement accuracy.
- ◆ In the figure, M-3 and M-4 show the wrong installation method. The M-3 installation method tends to accumulate air bubbles, which affects the measurement accuracy. Although the M-4 is a vertical installation method, there is no back pressure at the rear end of the watch, which may cause The fluid cannot completely fill the pipe, affecting the measurement accuracy.

3 water meter installation precautions

3.1 Newly installed pipes It is necessary to flush the sand, sand, hemp and other debris in the pipe before loading the watch to avoid water meter failure.

3.2 When installing the water meter, pay attention to the connection length of the water meter. When the distance between the two ends of the pipeline exceeds the connection length of the water meter, the pipeline spacing should be corrected to meet the connection length of the water meter. Otherwise, the excessively large installation will cause the water-end connection thread end to break or the pipe joint. Breakage and damage of the connecting nut; if the pipes at both ends of the water meter are not on the same axis, the pipeline should be corrected on the same axis by other means to meet the installation size of the water meter.

3.3 For accurate measurement, the faucet should be higher than the water meter.

3.4 In order to ensure the measurement accuracy, the general condition should keep the straight pipe section above 10D before the table. The straight pipe section above 5D should be kept after

the table, and the interference of elbow, tee, cone pipe and pump should be avoided as much as possible (D is the pipe diameter). If the pipe in front of the table has a reduced diameter pipe, the straight pipe section in front of the table is above 15D; when the pipe in front of the pipe has a 90° elbow, the straight pipe section in front of the table is above 20D; when the pipe in front of the pipe has a half-opening valve, the straight pipe section in front of the table Above 50D.

3.5 If the water meter is installed at the water inlet of the boiler, a check valve should be installed at the water outlet end of the water meter, and the water meter should be kept away from the check valve as much as possible to avoid the heat conduction of the metal pipe and the hot water returning to burn the water meter.

3.6 In order to make the water meter work normally for a long time, the water meter should always be filled with water. If air is likely to enter the water meter, install a bleed valve upstream of the water meter.

3.7 The water meter shall be prevented from being damaged by the impact or vibration of the surrounding environment of the installation site. The water meter shall also be protected from excessive stress caused by the pipe and the pipe fittings. If necessary, the water meter shall be installed on the base or the bracket.

3.8 It should prevent the extreme water temperature and extreme temperature from damaging the water meter and preventing the external environment from corroding the water meter.

3.9 Measures should be taken to prevent unfavorable hydraulic conditions (cavitation, surge, water hammer).

3.10 The upstream and downstream water pipes shall be properly fixed to ensure that no part will be displaced by the thrust of the water when the water meter is removed or the connection is disconnected.

3.11 During the long-term use of water meters, if there are debris, rust and other deposits in the pipeline, it will inevitably block the water filter network and affect the water supply and accurate metering. If the above situation occurs, it should be contacted and solved by the local water company. Installed.

3.12 When the water meter is not in use, if the liquid crystal shows a cumulative flow, if the water pressure in the pipeline is not stable enough or other reasons, it is recommended to close the control valve upstream of the water meter when the water meter is not in use. This phenomenon occurs when the inlet of the water meter is equipped with a check valve.

3.13 The water meter should not be directly connected with the pipeline. The water meter and the pipeline should be connected through the connecting pipe, the sealing gasket and the connecting nut. When disassembling and disassembling, the force should not be hardened to avoid twisting.

3.14 When installing a water meter with water saving function, it is necessary to use a special pipe joint at the water inlet to reduce the water table rotation caused by water pressure fluctuation.

3.15 The installation of the water meter or its accessories is not carried out in strict accordance with the installation precautions, and all losses shall be borne by the installer.

4 Instructions

4.1 Please read the “Instructions for Use” carefully before use.

4.2 This water meter is a fixed water meter installed in the residential, commercial and light industry (E1 class) and installed indoors (Grade B)

4.3 If the electronic part fails, the measurement is based on the mechanical count.

4.4 The company's instruction manual does not have any express or implied warranty. The company has the right to change and amend this manual. All changes are subject to change without prior notice.

4.5 Function menu display interface

4.5.1 Ultrasonic water meter user menu: page turning with magnetic switch pen to switch

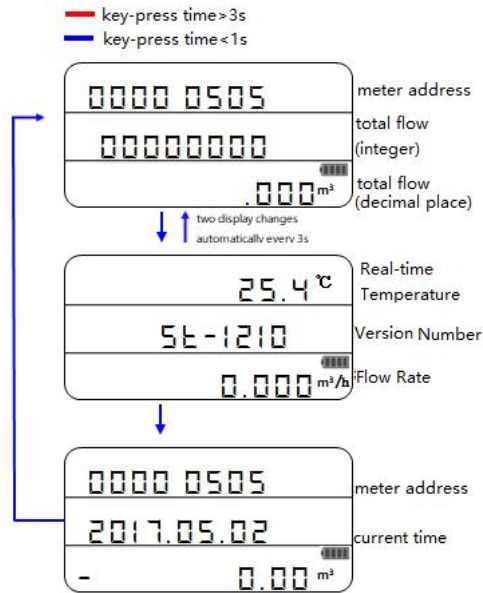

Figure 2- 3 User Menu

4.5.2 Ultrasonic Water Meter Verification

In the main menu interface, the cumulative flow interface is displayed with the magnetic switch pen long suction switch for 3s and then enters the detection interface [F]. The short suction switch is detected on the detection interface to query the current verification data. After 3 seconds of long-term absorption or 2 hours after the time has elapsed, the calibration interface will automatically leave.

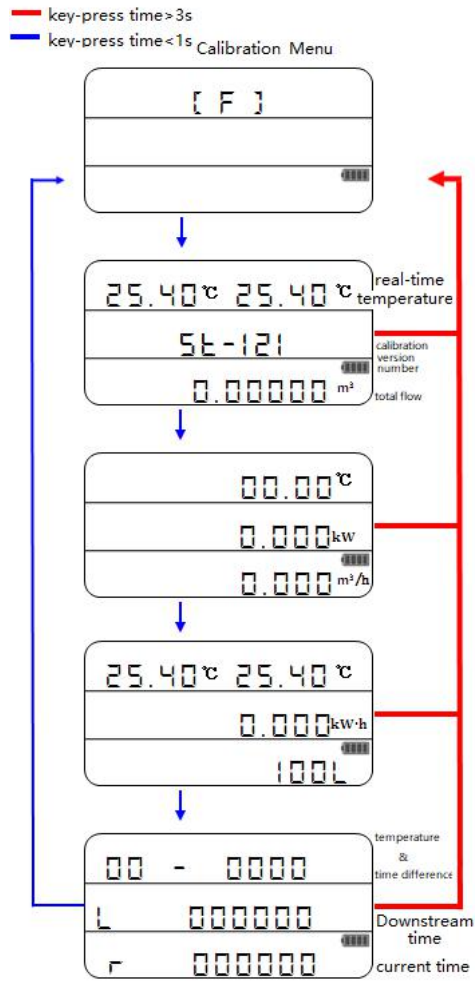

Figure 2-4 Ultrasonic Water Meter Verification

Diameter	Permanent Q ₃ (m ³ /h)	Transitional Q ₂ (m ³ /h)	Minimum Q ₁ (m ³ /h)	Overload Q ₄ (m ³ /h)
DN50	25	0.2	0.125	31.25
DN65	40	0.320	0.2	50
DN80	63	0.504	0.315	78.75
DN100	100	0.8	0.5	125
DN125	160	1.280	0.8	200
DN150	250	2	1.250	312.5
DN200	400	3.2	2	500
Measurement Accuracy	Q ₂ ≤Q≤Q ₄ ±2% Q ₁ ≤Q<Q ₂ ±5%			
Range Ratio	Q ₃ /Q ₁ =200, Q ₂ /Q ₁ =1.6, Q ₄ /Q ₃ =1.25			
Connection	flanged joint			
Pressure Loss	Δp40			
Pressure Level	MAP10 or MAP16			
Data Storage	Data storage for continual 18 months			
Power-off Protection	the data of accumulated flow and corresponding time will be saved once power failure takes place, and the meter works automatically as soon as the power restoration			
Remote Transmission	Standard Infrared, LoRaWAN, Wired M-BUS, RS485, PulseOutput			
Power Supply	Lithium Battery Power Supply /Remote Power Supply			
Protection Class	IP68			
Work Environment	Temperature: -25°C~+55°C, Environment Relative Humidity: <90%			
Installation	Horizontal or Vertical			
Service Life	life time≥10 years			

Table 2- 1 Flow Parameter

Part 3 Dimensions

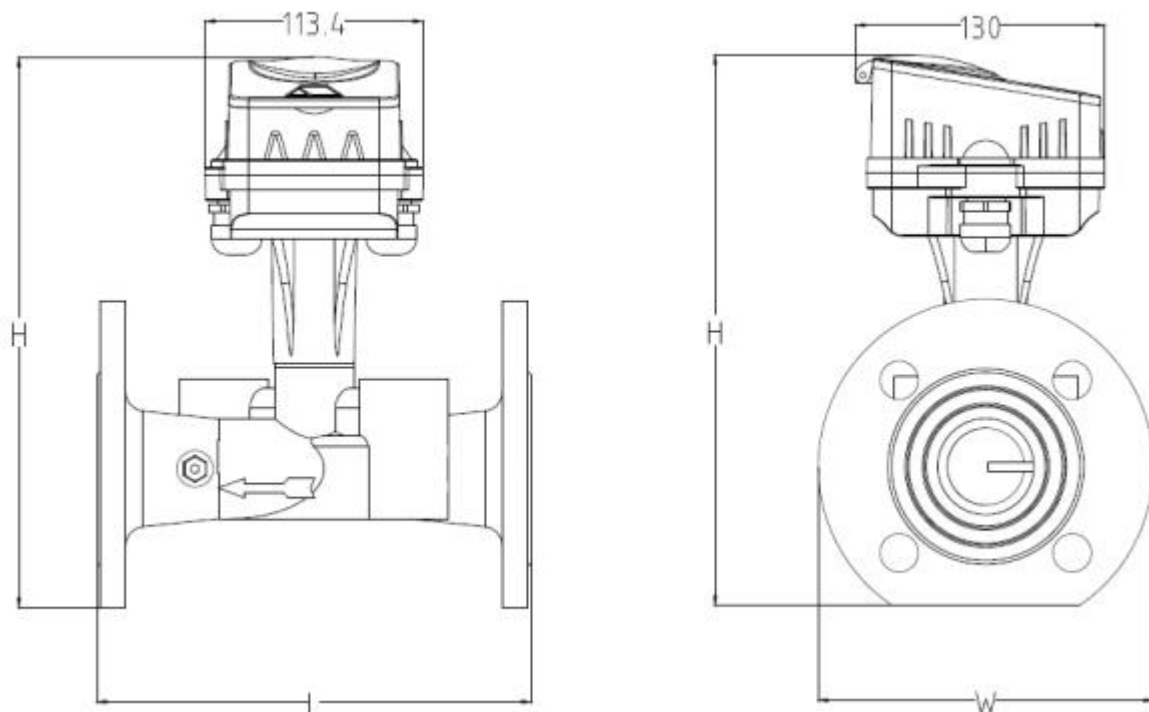

Figure 3- 1 Dimensions -sketch map

Nominal Diameter	L(mm)	H(mm)	W(mm)	Md	Bolt Hole Qty
DN50	200	220	170	M16	4
DN65	200	240	185	M16	4
DN80	225	255	250	M16	8
DN100	250	275	270	M16	8
DN125	250	305	300	M16	8
DN150	300	335	330	M20	8
DN200	350	395	380	M20	8

Table 3- 1 Dimensions -sketch map

Table 3-2 Product accessories list

No.	Name	Unit	Quantity	Remarks
1	Ultrasonic Water Meter	piece	1	
2	Product Manual	piece	1	
3	Certificate of Compliance Card	piece	1	

Part 4 Disclaimer

If the lead is destroyed or incomplete, the company is not responsible; and the company does not bear other related responsibilities beyond the water meter (including but not limited to the responsibility of water metering disputes caused by water meter failure or error).

Our company supplies repair parts for units that use our products for self-repair, but we need to get in touch with our sales department to provide repair parts in time.

Part 5 Transportation and Storage

The water meter shall be stored in the original packaging at an ambient temperature of 5 ° C - 40 ° C in an environment free of corrosive gases in the air.

When the water meter is stored on the shelf, the whole container stack height does not exceed 5 boxes.

Part 6 Troubleshooting

1. Detach the inspection by a professional;
2. the water meter shows a negative number

Check if the water inlet and outlet direction are reversed. If it is not the above problem, please return it to the original factory for settlement.

3. the water meter data is abnormal or jump

1) the installation location is not correct, installed in the lower water level

2) The straight pipe section is too short, the curve is too big, and the pipe diameter in front of the table is relatively large.

- 4, the water meter has flow without temperature

Do not dismantle it privately and return it to the original factory for settlement.