

Valve Control Ultrasonic Water Meter Instructions LXC-15E-20E



Content

1	Brief Introduction.....	1
2	Technical Details.....	1
2.1	Basic technical details.....	1
2.2	Flow Parameters.....	2
3	Network Topology: LoRaWAN 868+ LoRaWAN Gateway	3
4	Overall Dimensions.....	3
5	Operation Instructions.....	4
5.1	Alarm Menu	5
5.2	LCD Menu	6
6	Installation and Connection.....	6
6.1	Installation and Connection Requirements	6
6.2	Meter Installation	7
7	Calibration.....	8
8	Trouble Removal.....	9
9	Parts List	9
10	Transportation and Storage	10
11	Disclaimer	10
	Appendix.....	11
	Appendix 1 Alarm Menu.....	11
	Appendix 2 LCD Menu.....	12

Tables

Table 2-1 Technical Details – 214C	2
Table 2-2 Flow Parameters.....	2
Table 4-1 Overall Dimensions	4
Table 6-1 Special Cases and Reserved Pipe Length.....	7
Table 8-1 Trouble Removal.....	9
Table 9-1 Parts List	9

Figures

Figure 3-1 Network Topology: LoRaWAN Wireless Network + LoRaWAN Gateway	3
Figure 4-1 Overall Dimensions	3
Figure 5-1 Meter Display	4
Figure 5-2 Alarm Menu.....	5
Figure 5-3 LCD Menu.....	6
Figure 6-1 Installation Method.....	8
Figure 6-2 Meter Installation (1).....	8
Figure 6-3 Meter Installation (2).....	8

1 Brief Introduction

- The LoRaWAN wireless valve-controlled ultrasonic water meter is a new type of intelligent all-electronic meter. It integrates measurement, display, valve control and LoRaWAN wireless communication and adopts micro-power technology to achieve accurate measurement with a minimum flow of 0.01 m³/h
- Achieve multi-angle installation and minimize the pipe pressure loss.
- Open/close valve to remotely control the water consumption via LoRaWAN communication.
- Dedicated to household measurement in residential quarters
- LoRaWAN wireless valve-controlled ultrasonic water meter can be connected to the GSM wireless concentrator produced by our company, using GSM mobile public network for data transmission to form a wireless monitoring system. It automatically reports abnormal status.
- Product Standards: factory verification standard.

2 Technical Details

2.1 Basic technical details

Parameter	Performance
Diameter (mm)	DN15, DN20
Q3/Q1	R250
Pressure Loss	Δp40
Measured Medium	water or homogeneous liquid * Pipes must be full with measured medium.
Accuracy	Class 2
Maximum Working Pressure	1.6 MPa
Work Environment	5°C~+55°C, ≤100%RH
Temperature Grade	T50
Sensitivity of Upstream Flow Field	U10
Sensitivity of Downstream Flow Field	D5
Climatic and Mechanical Environmental Grades	B
EMC Grade	E1
Keypad	magnetic induction key

LCD		LCD 8 digits + prompt
Menu Contents		instantaneous flow(m ³ /h), cumulative flow(m ³), screen detection, meter address, cumulative working time(h), date(yy-mm-dd), software version
Display Range		cumulative flow: 0m ³ ~ +99999.999m ³
Communication	Photoelectric Interface	baud rate: 2400bps/ 9600bps based on CJ/T 188 self-defined protocol
	Wireless Interface	modulation mode: LoRaWAN frequency: 865MHz, 868MHz, 902MHz, 915 MHz and others transmission distance ≥ 3000m based on CJ/T 188 self-defined protocol
Power Supply		1. Battery power supply DC3.6V (work for continuous 8 years) 2. 24V external power supply (optional)
Power Consumption		<0.2mW
Waterproof Rate		IP68
Storage Temperature		-25°C~+55°C
Cable Length		1.0m
Installation Position		inflow pipe

Table 2-1 Technical Details – 214C

2.2 Flow Parameters

Diameter	Permanent Q₃ (m³/h)	Transitional Q₂ (m³/h)	Minimum Q₁ (m³/h)	Overload Q₄ (m³/h)
DN15	2.5	0.016	0.010	3.125
DN20	4.0	0.0256	0.016	5.0

Table 2-2 Flow Parameters

3 Network Topology: LoRaWAN EU868/US915+ LoRaWAN Gateway

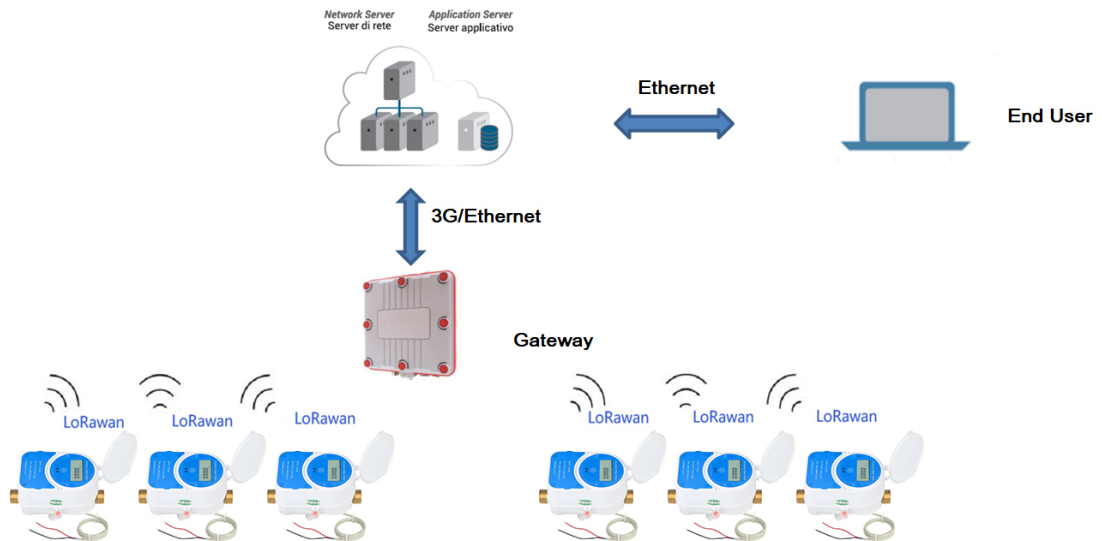

Figure 3-1 Network Topology: LoRaWAN Wireless Network + LoRaWAN Gateway

4 Overall Dimensions

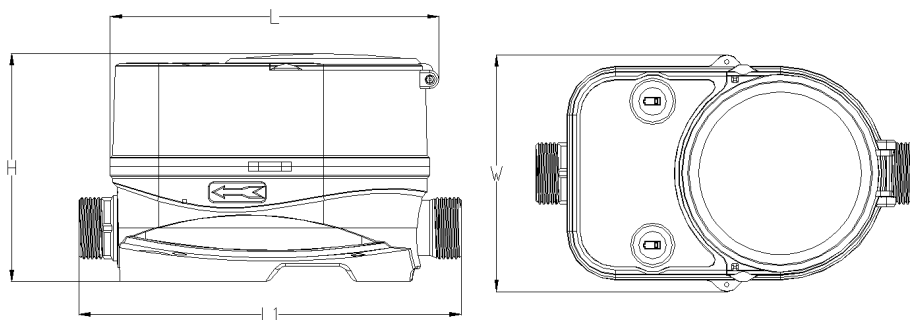

Figure 4-1 Overall Dimensions

Diameter(mm)	Thread	L (mm)	W (mm)	H (mm)
DN15	G ³ / ₄ B	165	102	98.2

DN20	G1B	195	102	98.2
------	-----	-----	-----	------

Table 4-1 Overall Dimensions

5 Operation Instructions

1. The LCD display main menu is divided into 4 modes: user mode, calibration mode, information mode and alarm mode.

2. In the user mode, touch the button to see accumulated flow, temperature, meter address, pressure, accumulated working time, date, diameter

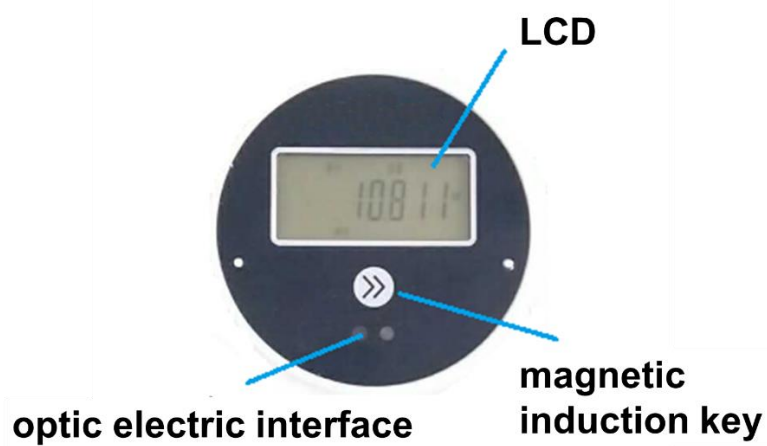

Figure 5-1 Meter Display

5.1 Alarm Menu

A. Water Meter Alarm



- undervoltage 0: normal 1: undervoltage
- abnormal transducer & empty pipe 0: normal 1: abnormal meter/empty pipe
- installation direction 0: normal 1: reverse installation
- pipe leak 0: normal 1: abnormal
- pipe burst 0: normal 1: abnormal

B. Valve Alarm



- valve status 0: valve open 1: valve closed 2: abnormal valve
- valve closed 0: normal 1: abnormal
- valve open 0: normal 1: abnormal
- forced to close valve 0: normal 1: abnormal
- forced to open valve 0: normal 1: abnormal

C. Power Alarm



- super-capacitor 0: normal 1: undervoltage
- internal battery 0: normal 1: undervoltage
- standby battery 0: normal 1: undervoltage
- M-BUS Trunk 0: normal 1: abnormal
- DC24V power supply() 0: normal 1: abnormal

D. Valve Status

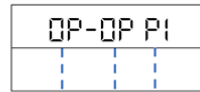

- motor power status P0: normal P1: undervoltage
- potential action of valve OP: normal CL: valve closed
- current valve status OP: normal CL: valve closed

Figure 5-2 Alarm Menu

5.2 LCD Menu

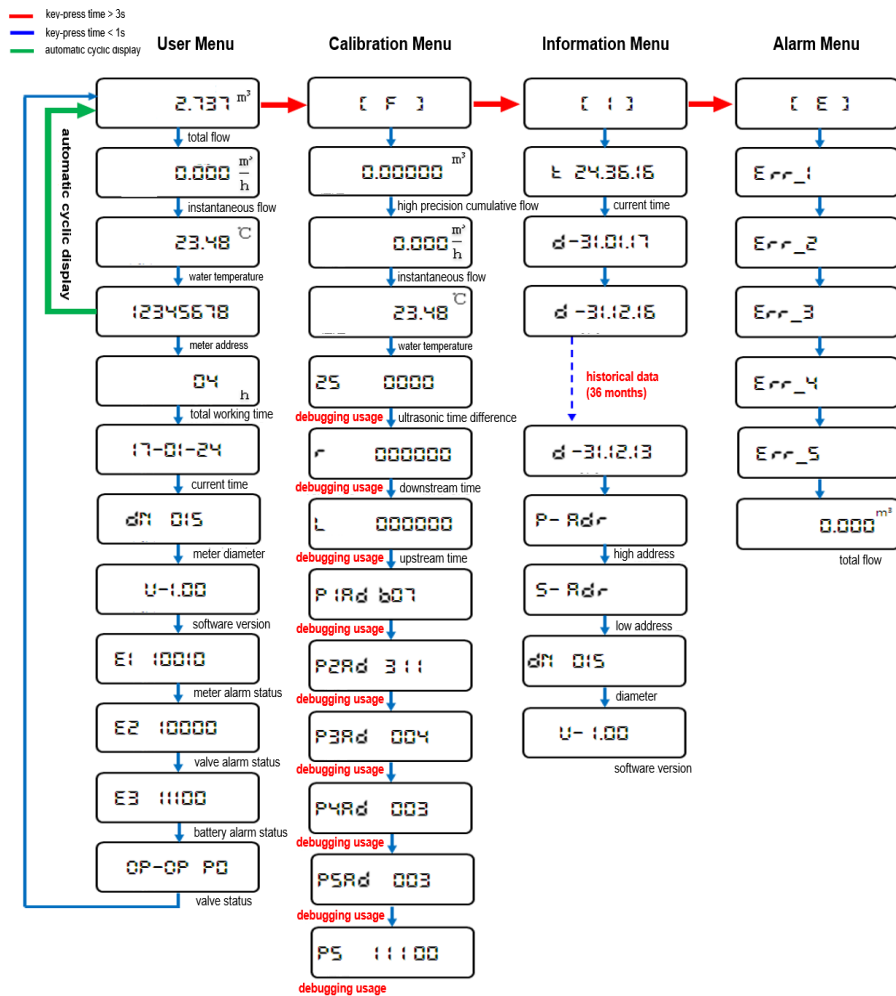

Figure 5-3 LCD Menu

6 Installation and Connection

6.1 Installation and Connection Requirements

- ✧ Install the meter in strict accordance with the requirements. Strictly forbidden to self-remove meter.
- ✧ Before installing the water meter, remove dirt and other rubbish in pipeline to avoid malfunction of water meter.
- ✧ Leave enough space for meter and connectors installation.

- ✧ To ensure the measurement accuracy, the reserved length space is the following. In the front of meter, the length space is over 10 times of diameter. Behind meter, the length space is over 5 times of diameter. Avoid the interference from elbow pipe, tee, cone pipe and pump. If there is a reduced diameter pipe installed before meter, the reserved length space will be over 15 times of diameter; if a 90° elbow, the length must be 20 times of diameter; if a half-opening valve, the space is over 50 times of diameter.

*D=diameter L _F = the length in the front of meter L _B =the length behind meter	
Special Case	Reserved Pipe Length
usual (normal installation)	L _F > 10D
	L _B > 5D
a reduced diameter pipe in the front of meter	L _F > 15D
a 90° elbow in the front of meter	L _F > 20D
a half-opening valve in the front of meter	L _F > 50D

Table 6-1 Special Cases and Reserved Pipe Length

- ✧ Avoid damage to the water meter caused by impact or vibration of the meter installation environment, and avoid damage caused by excessive stress from pipes and fittings. If necessary, please install the water meter on the base or bracket.
- ✧ Prevent extreme water temperature, extreme temperature, and external environment corrosion to water meter damage.
- ✧ Avoid cavitation, surge and water hammer.

6.2 Meter Installation

- The installed pipe must be filled with water. Install the meter on a vertical pipe in which the liquid flows upwards or diagonally upwards. If not, select a horizontal pipe. Try to AVOID installing the meter in a vertical pipe with the liquid flowing downwards or diagonally downwards.
- AVOID installing meter at the highest point of pipeline to prevent the air bubbles accumulated and interfere with measurement.

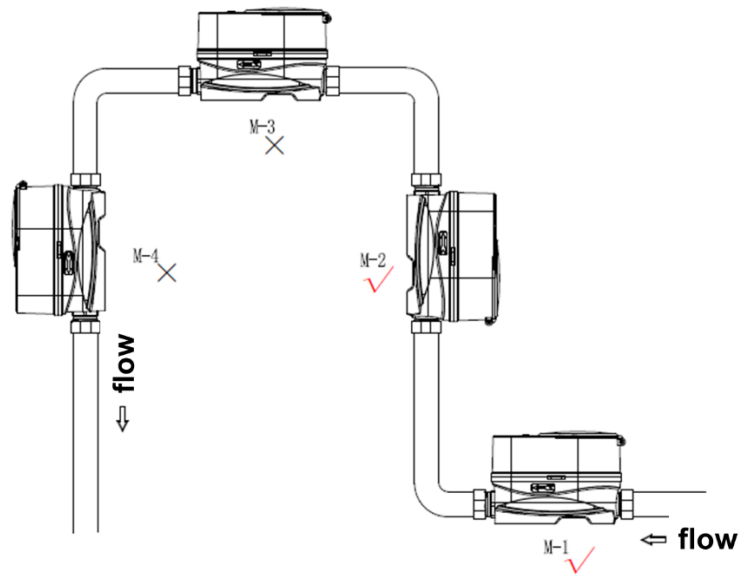

Figure 6-1 Installation Method

- Reserve a space at the water pipe for meter installation.



Figure 6-2 Meter Installation (1)

- Concentrically align meter with pipe. Use a wrench to connect the pipe blade to meter thread and tighten it.

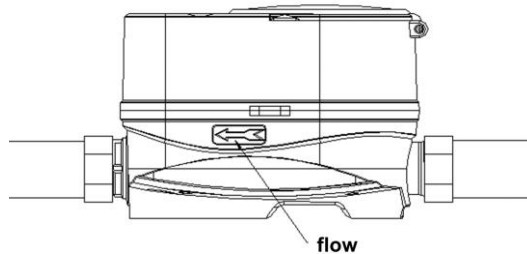

Figure 6-3 Meter Installation (2)

7 Calibration

It conforms to *JJG 162-2009 Cold Water Meter Calibration Regulations*.

8 Trouble Removal

No.	Malfunction	Description	Solution	Notes
1	Low Voltage	LCD displays 	Please change a new battery.	
2	Reverse Flow	LCD displays a negative number	Install meter in right direction.	Please send meter back to factory if this problem can't be solved in this way.
3	Install Meter Downstream	(1) abnormal data (2) data jump disorderly	Install meter according to instructions.	
	Insufficient Reserved Place in the Front of/Behind the Meter			
	Great Bend in the Front of/Behind the Meter			
	The Pipe Diameter Changes Greatly in the Front of/Behind the Meter			
4		LCD displays flow but without temperature		Do not dismantle without permission. Please return meter to factory for settlement.

Table 8-1 Trouble Removal

9 Parts List

No.	Item	Unit	Quantity	Notes
1	Water Meter	piece	1	
2	Product Manual	piece	1	
3	CERTIFICATION & Warranty Card	piece	1	
4	Sealing Ring	piece	2	
5	Connector Screw	piece	2	optional
6	Connector Nut	piece	2	optional

Table 9-1 Parts List

10 Transportation and Storage

- Keep meter in original package
- Store in non-corrosive, 5 ° C - 40 ° C environment.
- Keep the stacking height LESS THAN 5 cartons.

11 Disclaimer

- This meter conforms to Class E1 (for residential, commercial, light industrial environment) and Class B (installed indoors).
- This manual does not contain any clear or implied warranties. Ningbo Well Energy Technology Co., Ltd. keeps all rights to make adjustments and amendments on this manual. Manual is based on actual products.
- Ningbo Well Energy Technology Co., Ltd. can accept NO liability resulting from the improper use or installation of this product.
- Ningbo Well Energy Technology Co., Ltd. can accept NO liability if the sealing lead is destroyed or incomplete.
- Ningbo Well Energy Technology Co., Ltd. can accept NO liability except meter malfunction and related liability (including but not limited to the liability of metering disputes caused by water meter malfunction).

Appendix

Appendix 1 Alarm Menu

A. Water Meter Alarm



- undervoltage 0: normal 1: undervoltage
- abnormal transducer & empty pipe 0: normal 1: abnormal meter/empty pipe
- installation direction 0: normal 1: reverse installation
- pipe leak 0: normal 1: abnormal
- pipe burst 0: normal 1: abnormal

B. Valve Alarm



- valve status 0: valve open 1: valve closed 2: abnormal valve
- valve closed 0: normal 1: abnormal
- valve open 0: normal 1: abnormal
- forced to close valve 0: normal 1: abnormal
- forced to open valve 0: normal 1: abnormal

C. Power Alarm



- super-capacitor 0: normal 1: undervoltage
- internal battery 0: normal 1: undervoltage
- standby battery 0: normal 1: undervoltage
- M-BUS Trunk 0: normal 1: abnormal
- DC24V power supply() 0: normal 1: abnormal

D. Valve Status



- motor power status P0: normal P1: undervoltage
- potential action of valve OP: normal CL: valve closed
- current valve status OP: normal CL: valve closed

Appendix 2 LCD Menu

- key-press time > 3s
- key-press time < 1s
- automatic cyclic display

